

PS-525

Pitot-Static/Air Data Tester



OPERATION AND MAINTENANCE MANUAL

For Models PS-525 and PS-525A

Preston Pressure LLC
2905 Rural Route 1
Garvin, OK 74736
580-286-3161

prestonpressure.com

Revision 4, August 20, 2009

PRESTON PRESSURE LLC

PS-525/PS-525A

USER AND MAINTENANCE MANUAL

TABLE OF CONTENTS

| | Page |
|---|------|
| Warranty and Liability Statement ----- | 2 |
| 1. General Information ----- | 3 |
| 1. Description ----- | 3 |
| 2. Pressure Sensors ----- | 3 |
| 3. Specifications ----- | 4 |
| 4. Power Supply ----- | 5 |
| 5. Vacuum and Pressure Pumps ----- | 6 |
| 6. Front Panel Layout----- | 6 |
| 7. Front Panel Description ----- | 7 |
| 2. Theory ----- | 10 |
| 1. Pneumatic Theory ----- | 10 |
| 2. Electronic Theory----- | 11 |
| 3. Electrical Theory ----- | 12 |
| 4. Decoder Reader Theory ----- | 12 |
| 3. Operation ----- | 13 |
| 1. Preliminary Information ----- | 13 |
| 2. Error Codes ----- | 13 |
| 2. Pre-testing ----- | 13 |
| 3. Testing Aircraft Pitot System ----- | 14 |
| 4. Testing Aircraft Static System ----- | 15 |
| 5. testing the Aircraft Pitot and Static systems simultaneously ----- | 15 |
| 6. Using the E.P.R. Function ----- | 16 |
| 4. Calibration Procedures ----- | 17 |
| 1. Altimeter Calibration ----- | 17 |
| 2. Airspeed Calibration ----- | 21 |
| 3. Decoder Reader Calibration ----- | 23 |
| 4. Calibration of Reservoir Gauges ----- | 23 |
| 5. Maintenance Repairs and Troubleshooting ----- | 24 |
| 1. Annual Maintenance ----- | 24 |
| 2. Troubleshooting ----- | 24 |
| 3. Pneumatic Diagram ----- | 28 |
| 4. Electrical Schematic ----- | 29 |
| 5. Power Supply Board Schematic ----- | 30 |
| 6. Shipping and Storage ----- | 31 |

WARRANTY AND LIABILITY STATEMENT

Preston Pressure warrants its products against defects in workmanship and material under normal, intended use for a period of two years from the date of purchase. The batteries are warranted for a period of 90 days from the date of purchase. Valves are warranted for a period of 180 days.

Preston Pressure's limit of liability shall be to repair or replace the product at their discretion. Transportation shall be pre-paid to the Preston Pressure factory or authorized service facility. Preston Pressure shall not be liable for any consequential damage expense.

This warranty shall be void if the product has been repaired or altered in any way that adversely affects its performance or reliability. This warranty shall be void if the product has been subject to abuse, misuse, contamination, negligence, accident, shipping damage, or improper operation.

Preston Pressure reserves the right, at its own discretion, to make changes in materials, designs, finish, or specifications, without obligation to install or incorporate such changes in products previously manufactured.

This warranty shall, at Preston Pressure's option, become void if the ownership is changed, unless the prior owner or proposed owner obtains written approval of continuation of coverage prior to the change of ownership.

Preston Pressure reserves the right to revise this manual and to make changes to content from time to time in the content thereof, without obligation to notify any person of such revision.

This device complies with part 15 of the FCC Rules. Operation is subject to the following two conditions: (1) This device may not cause harmful interference, and (2) this device must accept any interference received, including interference that may cause undesired operation.

CHAPTER 1

GENERAL INFORMATION

Description of the PS-525 Pitot-Static Test Box

The PS-525/PS-525A Air Data, pitot-static test box is a digital display tester used to test aircraft altimeters, airspeed indicators, pitot-static systems, and other vacuum and low-pressure devices. This test box incorporates transducer sensor technology that is largely immune to the failures and costly repairs associated with analog instruments.

The PS-525 is battery powered, and portable. (A non-battery version is also available.) The vacuum and pressure sources are derived from independent internal pumps, and each has its own reservoir, thus eliminating the complexity and maintenance of an additional pressure/vacuum selector valve. The tester can simulate pressure and vacuum suitable for up to 35K ft (for the PS-525 models), (50K ft for the PS-525A models) and 500 Knots.

The PS-525 measures altitude in feet and meters. Airspeed is displayed in miles-per-hour, kilometers-per-hour, and knots. Vacuum and pressure are also selectable in various units of measure, including inches Hg, milliBars, mm Hg, and Psia.

The PS-525 also includes an internal digital altitude encoder reader. This reader can measure encoder outputs from -1200 feet to 62,700 feet. Inputs can be selected from either gray code or RS232.

- **Pressure Sensors**

The sensors used in the PS-525 test box are proprietary transducer sensors assembled by Preston Pressure. The pitot sensor is not a differential pressure sensor as is most typically used. Instead, the pressure information from the static sensor is sent digitally to the airspeed's microprocessor, where it is subtracted mathematically from the pitot pressure, thus giving the differential pressure value. This design eliminates several components, with their associated costs and maintenance.

The sensor has an overpressure rating of 10 times the normal range.

PS-525 SPECIFICATIONS

Digital Altimeter:

Display Range – model PS-525: -1000 to 35,000 feet (-305 to 10,700 meters)

Display Range – model PS-525A: -1000 to 50,000 feet (-305 to 15,240 meters)

Vacuum Pump Range – model PS-525: -1000 to 35,000 feet (-305 to 10,700 meters)

Vacuum Pump Range – model PS-525A: -1000 to 50,000 feet (-305 to 15,240 meters)

Resolution: from -1500 to 20,000 feet resolution is in 1-foot increments
from 20,001 to 30,000 feet resolution is in 2-foot increments
from 30,005 to 50,000 feet resolution is in 5-foot increments
all metric resolution is in 1-meter increments

Sensor Accuracy: approximately 0.03 %

Temperature range: 32 degrees F to 120 degrees F (0 C to 50 C)

Altitude units: Feet or Meters

Other Measurement Units:

inHg (inches of mercury): 0.295 to 32.48 in increments of 0.01

mBar (milli bars): 10 – 1100 in increments of 0.1

PSIA (pounds/square inch): 0.145 to 15.95 in increments of 0.01

mm HG (millimeters of mercury): 7.5 – 825 in increments of 0.1

Digital Airspeed:

Range: 18 – 500 Knots, 34 – 920 KPH, or 21 – 575 MPH

Resolution: 1 MPH, 1 KPH, or 1 Knot

Sensor Accuracy: approximately 0.03%

Temperature range: 32 degrees F to 120 degrees F (0 C to 50 C)

Other Measurement Units:

inHg (inches of mercury): 0.295 to 32.48

mBar (milli bars): 10 – 1100

PSI (pounds/square inch) 0.145 to 15.95

mm HG (millimeters of mercury): 7.5 – 825

E.P.R. (engine pressure ratio): 0.07-6.00

Display Type: LCD **Size:** Altimeter and Airspeed: 99 x 24 mm Decoder display: 38 x 16 mm

Physical Dimensions: 10.5”D X 14.25”L X 10”H (27x35x25 cm)

Weight: approximately 20 lbs (9 Kg)

Decoder Inputs: Gray Code, RS232: 1200, 2400, & 9600 baud

Power Source:

External: 24 VDC (from a 110/220 VAC adaptor)

Internal: 12/24 VDC (from internal rechargeable batteries)

Optional: 110/220 VAC Mains powered, without internal batteries

Current draw: Display only: 125 mA

370 mA with vacuum pumps operating

320 mA with pressure pump operating

540 mA with all systems operating (and no encoder attached)

Other Features:

Leak test feature: 2 minutes, selectable down to 30 seconds (longer test periods available upon request)

VSI (vertical speed indicator) : Limited to 10,000 ft/minute

Note: The PS-525 does NOT have the precision required to test RVSM altimeter systems.

Encoder Reader:

The Encoder Reader is compatible with outputs of the following altitude encoders:

ACK (gray code, 1200, 2400, 9600 baud)
Shadin (gray code, 9600 baud)
Trans-Cal (gray code, 1200, 2400, 9600 baud)
Ameri-King (gray code)

The Encoder Reader is compatible with the following RS-232 protocols:

Garmin 1200, 9600 baud
Northstar 2400 baud
Shadin 9600 baud
UPS AT, Apollo 1200 baud
Trimble 9600 baud

- **Power Supply**

The PS-525 power supply consists of an external transformer with an output of 24 volts DC. This supply is plugged into the round connector on the left-hand side of the tester. The transformer charges the two 12-volt gel-cell lead acid batteries that are internal to the PS-525. The batteries enable the test box to be used in a portable fashion, without a need for external power while the tester is in operation. The test box can be used while charging, if so desired, and may be mounted in any position or angle.

The PS-525 incorporates a trickle-charge circuit that will maintain the batteries at optimum voltage if left charging continuously, and will not over-charge.

A battery monitoring circuit is also incorporated. This circuit disconnects power to the motors if the battery voltage drops below 18 VDC. This enables the display to continue working, and prevents the user from having the display suddenly blank out if the voltage goes too low when a motor is turned on. The decoder display will flash a “Low Battery” warning when the battery voltage is near 18.5 volts. The purpose for this circuit is to protect the batteries from excessive discharges.

The “Select Code” button may be pressed to toggle the decoder display to a setting that will read the battery voltage (not the voltage going to the encoder). This enables the operator to maintain awareness of the battery voltage level. The useable charge duration of the batteries will vary, mostly depending on how long the vacuum and pressure pumps are left on. **In order to obtain maximum charge durability, as well as extend pump and battery life, it is recommended that the pumps be left on only for the amount of time needed to charge their respective reservoirs, as shown in the gauges. Then the pumps should be cycled on and off as needed.** When used properly, the user should be able to obtain several hours of operation directly from the batteries before needing to re-charge. In factory tests, with fully charged batteries, the batteries lasted for over 12 hours when powering only the displays.

Vacuum and Pressure pumps should not be allowed to run continuously. Toggle the switches as needed to re-charge the reservoirs as seen on the vacuum and pressure gauges.

OPTIONAL: 110/220 VAC mains powered without internal batteries. In this case, the batteries are replaced by two internal transformers of 12 VDC each. These transformers replace the batteries. The unit is powered with a standard power chord.

- **Vacuum and Pressure Pumps**

The vacuum side uses two pumps, connected in series to achieve a vacuum level required for high altitude tests. The pressure side uses one pump, which is sufficient to reach all the pressures necessary for normal pressure tests.

FRONT PANEL LAYOUT



Front Panel Description

- The front panel's **Altimeter** buttons function as follows:

The **UNITS** button is used to toggle between the various units of measurement available from the vacuum/altimeter section. (Altitude – feet, Altitude – meters, mBar, mmHg, inHg, PSIA)

The **EXIT** button is used to exit out of the leak check mode.

The **LEAK CHECK** button is functional only when in the Altimeter mode. Pressing this button will begin a 120 second timer, and the display will also show the gain or loss of altitude experienced during the displayed time period. If the operator wishes to select a different length of time, the Leak Check button may be pressed repeatedly, which will cause a reduction in the timer counter in 30-second increments. The timer will not toggle above 120 seconds nor under 30 seconds. Pressing the Units button will start the counter and display the leakage.

- The front panel's **Airspeed** buttons function as follows:

The **UNITS** button is used to toggle between the various units of measurement available from the pressure/airspeed section. (Airspeed – MPH, Knots, KPH, mBar, mmHg, inHg, PSIA, EPR)

The **EXIT** button is used to exit out of the leak check mode.

The **LEAK CHECK** button is functional only when in the Airspeed mode. Pressing this button will begin a 120 second timer, and the display will also show the gain or loss of airspeed experienced during the displayed time period. If the operator wishes to select a different length of time, the Leak Check button may be pressed repeatedly, which will cause a reduction in the timer counter in 30-second increments. The timer will not toggle above 120 seconds nor under 30 seconds. Pressing the Units button will start the counter and display the leakage.

- The front panel's **Select Code** functions as follows:

Upon initial power application, the decoder will always default to the Gray Code function. Pressing the Select Code button will cause the decoder to toggle through the following functions, after which it will return to the Gray Code function again:

- Gray Code – altitude numerical readout
- Gray Code – inputs A1, A2, A4 binary readout
- Gray Code – inputs B1, B2, B4 binary readout
- Gray Code – inputs C1, C2, C4 binary readout

- Gray Code – input D4 binary readout
- Battery voltage (used to monitor the voltage level of the tester’s internal batteries). This is not necessarily the voltage going to the encoder, which is selected by the power switch.
- 1200 Baud rate, from Port A (pin 14 of front encoder connector)
- 1200 Baud rate, from Port B (pin 7 of front encoder connector)
- 2400 Baud rate, from Port A (pin 14 of front encoder connector)
- 2400 Baud rate, from Port B (pin 7 of front encoder connector)
- 9600 Baud rate, from Port A (pin 14 of front encoder connector)
- 9600 Baud rate, from Port B (pin 7 of front encoder connector)

The Encoder Reader is compatible with outputs of the following altitude encoders:

ACK (gray code, 1200, 2400, 9600 baud)
 Shadin (gray code, 9600 baud)
 Trans-Cal
 Ameri-King (gray code)

The Encoder Reader is compatible with the following RS-232 protocols:

Garmin 1200, 9600 baud
 Northstar 2400 baud
 Shadin 9600 baud
 UPS AT 1200 baud
 Trimble 9600 baud

Note: The **Power Switch** may be toggled up or down. Either position will turn on the test box. The only difference is that in the UP position the switch will transfer 24 VDC to the encoder connector (pin 8), and in the DOWN position the switch will transfer 12 VDC to the encoder connector (pin 8). **The position of this switch does not change the voltage going to the PS-525 display circuitry, which always operates at 24 VDC.**

CHAPTER 2

THEORY

The PS-525 test box consists of two vacuum pumps linked in series, one pressure pump, reservoirs for the pressure and vacuum, a system of metering valves, and digital displays for indicating altitude, airspeed, and various other pressure measurements, based on pressures sensed in the sensor transducers.

- **Pneumatic Theory**

Metering valves allow the operator to control the rate of flow of the air from the pressure or vacuum sources, exiting out through the vacuum and pressure ports. The vent valves allow for metering the produced vacuum or pressure back into the atmosphere. One crossbleed valve permits the operator to isolate the pressure and vacuum sides, or to allow the balancing of pressures, or even to reverse the normal flow of pressures.

The two round gauges allow the operator to monitor the level of pressure or vacuum that is stored in the tester's reservoirs. The switch corresponding to the pump for each reservoir should be toggled to increase the reservoir's level of vacuum or pressure as needed. For maximum pump and battery life, **do not leave pumps on continuously!**

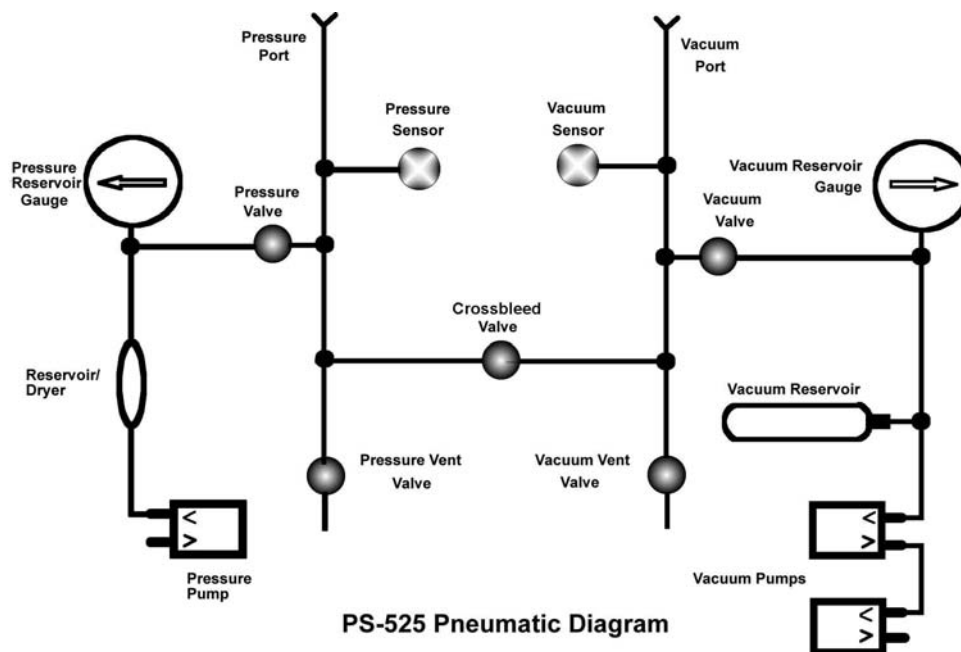

When the operator wishes to simulate an altitude, the Crossbleed, Vacuum, and Vacuum Vent valves are gently closed. The vacuum pump is then energized until sufficient vacuum is in the reservoir, as indicated on the Vacuum Reservoir Gauge. How much vacuum will be needed depends on the desired altitude, and is also affected by how long the tubing and lines are between the test box and the altimeter. **The vacuum and**

pressure reservoir gauges serve only as general references of reservoir vacuum and pressure; they are not used in the actual calibration of any instrumentation, and do not require calibration. Once sufficient vacuum is obtained in the reservoir, the pump is turned off, and the Vacuum Valve is gently opened to allow air to be suctioned into the system through the vacuum port. Once sufficient altitude simulation is obtained, the Vacuum Valve is gently closed. Reduction in altitude is accomplished by gently opening the Vacuum Vent Valve, and allowing atmospheric air pressure to enter into the lines.

If the operator needs to go to an altitude below atmospheric pressure, pressure must be introduced into the pressure reservoir. Opening the Crossbleed Valve will enable pressure to flow from the pressure reservoir to the altimeter. Open the Crossbleed valve, and then the Pressure valve to pressurize the vacuum side.

Similarly, when airspeed is to be simulated, the Crossbleed, Pressure and Pressure Vent valves will first be closed, until the operator establishes a pressure build-up in the pressure reservoir by turning on the pressure pump. Then the Pressure Valve will be gently opened, allowing air pressure to flow through the pressure port to the airspeed indicator. To reduce pressure, the Pressure Vent valve is opened to leak the air pressure into the atmosphere.

- **Electronic Theory**

The main circuit board of the PS-525 incorporates all the electronics for the altimeter, decoder, and airspeed indicators. The switch on the top of the circuit board allows the operator to select encoder power as being either 12 or 24 Volts DC. Each of the three circuits utilizes its own microcontroller and power supply. The power for the altimeter, airspeed, and decoder circuits is regulated from the 24 VDC to 5 VDC and 3.3 VDC. **Toggling the switch between 24 VDC and 12 VDC will have no effect on the power going to the altimeter, airspeed, and decoder circuits.**

The sensors used in the PS-525 test box are proprietary transducer sensors assembled by Preston Pressure. The pitot sensor is not a differential pressure sensor as is most typically used in airspeed measurements. Instead, the pressure information from the static sensor is sent digitally to the airspeed's microprocessor, where it is subtracted mathematically from the pitot pressure, thus giving the differential pressure value. This design eliminates several components with their associated costs and maintenance. It also allows the Altimeter side to be used at any altitude with the Crossbleed valve closed, without damaging the airspeed sensor.

Warning: Even though the pressure sensors will not be damaged due to a high differential pressure between the vacuum and pressure sides, damage can still occur in external instruments connected to the test box.

- **Electrical Theory**

Two internal gel-cell lead-acid batteries, or two internal transformers (depending on options) provide the power to the PS-525 test box. The batteries are charged via the power connector on the side of the test box. Full charging time is about 10 hours. **The test box can be used while it is being charged.**

The two batteries provide a voltage output of +12 or +24 Volts DC. This allows the operator to switch between the voltages, depending on which type of encoder is being tested.

An electrical schematic of the test box and the power supply board is located in the Repairs and Troubleshooting chapter.

- **Decoder Reader Theory**

A front panel connector is available to allow the monitoring of encoded altitudes as reported from various types of encoders. This encoded altitude may be read simultaneously with the altimeter readings, in order to calibrate the two systems to read in unison. Various cables may be fabricated to enable the operator to connect any of the current encoders to be tested with the PS-525 test box. Cables are not provided due to the many differing pin-outs in the industry.

The reader circuit will convert Gray Code and RS 232 at speeds of 1200, 2400, and 9600 baud, into alpha-numeric symbols for the operator to read. The operator may choose which code and which port to use by pressing the “Select Code” button beneath the decoder display. The power switch on the front of the test unit allows the operator to select either +12 or +24 volts for the encoder’s power.

The decoder defaults to Gray code upon powering up. Pressing the “Select Code” button five times will change the display to read the battery voltage (not the voltage going to the encoder). This enables the operator to maintain awareness of the battery voltage level.

The pin-out of the connector is as follows:

| Pin # | Function | Pin # | Function |
|-------|------------------|-------|------------------|
| 1 | D4 | 10 | B4 |
| 2 | A1 | 11 | C1 |
| 3 | A2 | 12 | C4 |
| 4 | A4 | 13 | C2 |
| 5 | B1 | 14 | RS 232 input # A |
| 6 | strobe ground | 15 | power ground |
| 7 | RS 232 input # B | | |
| 8 | +12 or +24 volts | | |
| 9 | B2 | | |

CHAPTER 3

OPERATION

- **Preliminary Information**

Prior to using the PS-525 tester, the user should become familiar with the unit by reading this manual and operating the tester independently of any other attached devices.

The test procedures described in this manual are general in nature, for reference use only. The operator may substitute these procedures with others, as applicable to the tests to be performed, or according to other specific documentation.

Error codes display as follows:

- The display will blink if altitude exceeds 35,200 feet, or if sensor temperature is below 32F or 0C, or above 122F or 50C. Beyond these limits the accuracy should not be trusted.
- Altitude displays “High Alt” if it exceeds 40,000 feet (50,050 ft for PS-525A).
- “Inverse Pressure” will be indicated on the airspeed side if the static pressure exceeds the pitot pressure by more than approximately 0.1 mbar. Due to its independent pressure and static sensors, no damage will occur to the tester due to inverse pressure. However, damage could occur to any system attached to the tester, therefore the warning is to alert the user of the condition.
- “Over Pressure” will be indicated on the airspeed side if the pressure exceeds the equivalent of 500 knots. Due to independent pressure and static sensors, no damage will occur to the tester due to this condition. However, damage could occur to any system attached to the tester, therefore the warning is to alert the user of the condition.

Be very gentle with the precision metering valves. Do not close these valves with unnecessary force, or internal damage to valve seating will occur.

- **Pre-Testing**

Pre-test the static system of the PS-525 test box according to the following steps:

1. Ensure the PS-525 is not connected to any external hoses or devices.
2. Close the Vacuum Control, Vacuum Vent, Pressure Control, and Pressure Vent valves. Open the Crossbleed valve.
3. Turn on the power, and then turn on the Vacuum Pump switch until the Vacuum Reservoir gauge reads approximately -15 inHG.
4. Gently open the Vacuum Control valve to make the Altimeter section climb. This climb may be done rapidly without damage to the sensor.

5. When the Altimeter reads at least 18,000 feet, gently close the Vacuum Control valve.
6. Wait for about 60 seconds for internal pressures to stabilize. Then perform a leak check.
7. The leak check function will activate and begin to monitor the leak rate. Verify that the PS-525 does not leak exceeding 100 feet per minute. Write down the leak rate for future reference. (Subtract this value from the total leak rate when testing the aircraft, to arrive at the aircraft's leak rate.)
8. Gently open the Vacuum Vent valve to bring the test box back to ground (ambient) pressure.

Pre-test the pressure system of the PS-525 test box according to the following steps:

1. Turn on the power to the PS-525.
2. Ensure the PS-525 is not connected to any external hoses or devices.
3. Close the Vacuum Control, Vacuum Vent, Pressure Control, Crossbleed valve, and Pressure Vent valves.
4. Turn on the Pressure Pump switch until the Pressure Reservoir gauge reads approximately 15 PSI.
5. Gently open the Pressure Control valve to make the Airspeed section climb. This climb may be done rapidly without damage to the sensor.
6. When the Airspeed reads at least 300 knots, gently close the Pressure Control valve.
7. Wait for about 30 seconds for internal pressures to stabilize. Activate the leak check function to monitor the leak rate. Verify that the PS-525 does not leak exceeding 2 knots per minute. Write down the leak rate for future reference. (Subtract this value from the total leak rate when testing the aircraft, to arrive at the aircraft's leak rate.)
8. Gently open the Pressure Vent valve to bring the test box back to ground (ambient) pressure.

Testing Aircraft Pitot System Only

1. Turn on the power to the PS-525.
2. Connect the Pressure Port to the aircraft Pitot system.
3. Close Pressure Control, Pressure Vent, and Crossbleed valves. Open Vacuum vent valve.
4. Turn Pressure Pump switch on until the Pressure Reservoir indicates 15 PSI or more.
5. Gently open Pressure Control valve until desired speed(s) are achieved.
6. Compare the airspeed of the PS-525 box to the airspeed indicated in the aircraft.
7. Go to approximately 75% of the maximum airspeed of aircraft indicator (or the speed specified by the manufacturer). Close the Pressure Control valve and after allowing a few seconds for stabilization, perform a leak check. The pitot system

should not leak more than two knots per second, plus the leakage previously noted in the pressure system pre-test.

8. Gently open the Pressure Vent valve to return the pitot pressure to ambient pressure.

Testing of Aircraft Static System

Note: If the previous pitot system test indicated an excessive leak, do not proceed until that leak is repaired. Damage to aircraft airspeed indicator could result.

1. Turn on the power to the PS-525.
2. Connect the Vacuum Port to the aircraft static port, and the Pressure Port to the aircraft pitot port. Set the aircraft altimeter to 29.92 inHg (1013.3 mB).
3. Close Vacuum Control, Vacuum Vent, Pressure Control, and Pressure Vent valves. Open Crossbleed valve.
4. Operate the Vacuum Pump switch until a desired level of vacuum is seen on the Vacuum Reservoir gauge (generally -15 to -20 inHG). Turn Pressure Pump switch on until the Pressure Reservoir indicates 15 PSI or more.
5. Gently open the Vacuum Control valve to cause the altitude to climb.
6. **DO NOT** exceed the climb rate of the aircraft VSI indicator, or the airspeed indicator limits. The VSI is a very delicate instrument.
7. Climb to the desired altitude(s) per the test to be performed.
8. Close the Vacuum Control valve, and after allowing a few seconds for stabilization, compare the aircraft altimeter with the test box.
9. When at the appropriate altitude (generally 18,000 feet) perform a leak check. If the static system shows leakage, be careful to not exceed the VSI rate. Be prepared to open the Vacuum Control valve if needed, to prevent excessive VSI indication.
10. Gently open the **Pressure Vent** valve to return the system pressure to ambient pressure. Do not exceed the VSI or airspeed indicator limits.

Note: if an altitude lower than ambient pressure is desired, do steps 1-4 above. Gently open the Pressure Control valve to pressurize the system, thereby causing the altimeter to decrease in altitude. Open the Vacuum Vent valve to return to ambient pressure.

Testing the Aircraft Pitot and Static systems simultaneously

Note: First ensure pitot system does not leak by performing Pitot system test on page 14.

1. Turn on the power to the PS-525.
2. Connect the Vacuum Port to the aircraft static port, and the Pressure Port to the aircraft pitot port. Set the aircraft altimeter to 29.92 inHg (1013.3 mB).
3. Close Vacuum Control, Vacuum Vent, Pressure Control, and Pressure Vent valves. Open Crossbleed valve.

4. Operate the Vacuum Pump switch until a desired level of vacuum is seen on the Vacuum Reservoir gauge (generally -15 to -20 inHG). Turn Pressure Pump switch on until the Pressure Reservoir indicates 15 PSI or more.
5. Gently open the Vacuum Control valve to cause the altitude to climb.
6. **DO NOT** exceed the climb rate of the aircraft VSI indicator, or the airspeed indicator limits. The VSI is a very delicate instrument.
7. Climb to the desired altitude(s) per the test to be performed.
8. Close the Vacuum Control valve, and after allowing a few seconds for stabilization, compare the aircraft altimeter with the test box.
9. When at the appropriate altitude (generally 18,000 feet) perform a leak check. If the static system shows leakage, be careful to not exceed the VSI rate. Be prepared to open the Vacuum Control valve if needed, to prevent excessive VSI indication.
10. To display an airspeed, close Crossbleed valve and gently open Pressure valve until desired airspeed is indicated. Close Pressure valve.
11. To return system to ambient pressure, ensure Crossbleed valve is open. Then gently open the **Pressure Vent** valve to return the system pressure to ambient pressure. Do not exceed the VSI or airspeed indicator limits.

Note: if an altitude lower than ambient pressure is desired, do steps 1-4 above. Gently open the Pressure Control valve to pressurize the system, thereby causing the altimeter to decrease in altitude. Open the Vacuum Vent valve to return to ambient pressure.

- **Using the E.P.R. function**

The EPR function is used to test engine pressure ratios. This ratio is the mathematic result of: High Pressure/Low Pressure. The PS-525 test box will display the low pressure, the high pressure (both in PSI), and the resulting EPR. To use the EPR function, proceed as follows:

1. Turn on the test box.
2. Close all of the valves, including the Crossbleed valve.
3. Connect the Vacuum port to the low pressure to be tested.
4. Connect the Pressure port to the high pressure to be tested.
5. Cycle through the Units on the Airspeed side until in the EPR mode. Read the EPR values displayed.

Note: Do not exceed 16.75 PSI on the high pressure side, to avoid sensor damage.

CHAPTER 4

CALIBRATION PROCEDURES

The recommended calibration interval for the PS-525 and PS-525A test box is one year. If at any time during regular use the unit becomes unreliable or out of correct operating calibration, it must be repaired and/or re-calibrated before continuing its use.

The PS-525 test box is easy to calibrate. There are 4 set points used in the calibration of the altimeter side (7 points for the PS-525A). Calibrating at multiple setpoints enables the altimeter to have a greater degree of accuracy, allowing it to self-correct to the nearest calibrated set point.

The altimeter side should normally be calibrated first, as the airspeed side reads the static pressure through the altimeter circuitry. However, if the altimeter side has been tested and found satisfactory, the airspeed side can be calibrated at any time.

Note: the calibration factors are stored in the microcontroller's EEPROM memory. This memory does not need battery back-up. The calibration will not be lost if the unit's batteries are disconnected or replaced.

PS-525 Altimeter Side Calibration Procedures

Note: the calibration procedures for the PS-525 and PS-525A are the same, except that the PS-525A has two additional calibration test points.

1. Apply power to the PS-525 display and allow unit to warm up for a *minimum* of 15 minutes.
2. Gently close the Vacuum Control valve, Vacuum Vent valve, and Crossbleed valve.
3. Connect a known altitude pressure standard to the Vacuum Port.
4. Set the PS-525 altimeter measurement units to read in mbar by pressing the Units button.
5. Press the Exit and Leak Check buttons simultaneously. The display will change to:

Calib? No Yes

6. Press the Leak Check button to proceed with calibration, or select the Exit button to exit out of the calibration mode without any changes being made.

7. At this point the display will read:

Goto 0 Feet
Nxt XXX ^YY v

Where XXX is the sensed altitude and YY is the internal correction factor currently stored in the calibration memory.

8. Using the pneumatics of the PS-525 or an attached pressure standard, go to a pressure of 0 feet (referenced from 29.92 inHg), as read from the pressure standard. When the altitude is stable for approximately 30 seconds, note the altitude displayed on the PS-525 display in calibration mode.

If the displayed altitude is lower than the standard, press the Exit button as needed to incrementally raise the altitude to be equivalent to the standard.

If the displayed altitude is higher than the standard, press the Leak Check button as needed to incrementally lower the altitude to be equivalent to the standard.

As the altitude is adjusted, note that the displayed correction factor also changes. Use this to fine-tune the altitude as close as you can to the standard.

When the PS-525 altitude matches the standard as close as possible, wait another 30 seconds to ensure that the internal mathematical filtering corrections have been done. If satisfied with the results, press the Units button to proceed to the next calibration level.

Note: Allowable error tolerances are as follows:

| Altitude | +/-Error | Altitude | +/-Error |
|----------|----------|----------|----------|
| -1000 | 5 | 14000 | 25 |
| 0 | 5 | 16000 | 27 |
| 500 | 5 | 18000 | 30 |
| 1000 | 5 | 20000 | 32 |
| 1500 | 6 | 22000 | 35 |
| 2000 | 7 | 25000 | 38 |
| 3000 | 7 | 30000 | 45 |
| 4000 | 8 | 35000 | 51 |
| 6000 | 10 | 40000 | 57 |
| 8000 | 15 | 45000 | 63 |
| 10000 | 20 | 50000 | 70 |
| 12000 | 22 | | |

Note: Make a written note of each calibration correction value. In the very rare case that a calibration factor is lost from the memory, it can be re-programmed without a complete calibration procedure. The correction values can also serve as a record to see if the sensors are drifting with age. A good place to keep the calibration correction values is in this manual.

After pressing the Units button, the display will go momentarily blank and change to display **Goto 10000 feet**. (Or, the operator may exit the calibration by turning the power off. The calibration for each range is saved every time the Nxt (Units) button is pressed.)

10. Repeat the procedure in step 9 at each requested altitude: 10000, 20000, and 30000, feet for the PS-525. The PS-525A requires additional calibration points at 40,000, 45,000 and 50,000 feet.

11. After the last calibration point has been entered, the display will briefly read “**Storing New Cal**” and then re-start in the mBar mode. There is no need to re-cycle power.

Note: The calibration values are stored in memory as they are being changed, not when exiting from the calibration mode.

12. While bringing the PS-525 box back down to ground level pressure, test each calibration point as specified in the chart. Enter the corrected value at each point. (The correction chart may be photocopied, cut out, and fixed to the test box for handy reference.)

Maximum allowable error at any altitude is 50 feet. (Generally, a maximum error of less than 20 feet should be expected.)

PS-525 S/N

| TEST ALTITUDE | DISPLAY ALTITUDE | TEST ALTITUDE | DISPLAY ALTITUDE |
|---------------|------------------|---------------|------------------|
| - 1000 | | 10000 | |
| 0 | | 12000 | |
| 500 | | 14000 | |
| 1000 | | 16000 | |
| 1500 | | 18000 | |
| 2000 | | 20000 | |
| 3000 | | 22000 | |
| 4000 | | 25000 | |
| 6000 | | 30000 | |
| 8000 | | 35000 | |

Calibrated by: _____ Date: _____
 Next Calibration Due Date: _____

PS-525A S/N

| FOR TEST ALTITUDE | DISPLAY ALTITUDE | FOR TEST ALTITUDE | DISPLAY ALTITUDE |
|-------------------|------------------|-------------------|------------------|
| - 1000 | | 14000 | |
| 0 | | 16000 | |
| 500 | | 18000 | |
| 1000 | | 20000 | |
| 1500 | | 22000 | |
| 2000 | | 25000 | |
| 3000 | | 30000 | |
| 4000 | | 35000 | |
| 6000 | | 40000 | |
| 8000 | | 45000 | |
| 10000 | | 50000 | |
| 12000 | | n/a | n/a |

Calibrated by: _____ Date: _____
 Next Calibration Due Date: _____

Airspeed Calibration Procedures

Note: the procedure is identical for both the PS-525 and PS-525A models.

1. Apply power to the PS-525 display and allow unit to warm up for a minimum of 15 minutes.
2. Gently close the Pressure Control valve, Pressure Vent valve, and Crossbleed valve.
3. Connect a known pressure standard to the Pressure Port. Or an alternate method may be to open the crossbleed valve to do the calibration when the altimeter side is done at 0 feet. (The airspeed calibration is done by direct pressure measurement, and not in a differential pressure mode.)
4. Press the Units button to set the airspeed measurement units to read in mbar.
5. Press the Exit and Leak Check buttons. The display will change to:

Calib? No Yes

6. Press the Leak Check button to proceed with calibration, or select the Exit button to exit out of the calibration mode without any changes being made.
7. At this point the display will read:

Goto 1013.25 mBar

Cal XXX ^YYv

Where XXX is the sensed pressure in mBars and YY is the internal correction factor currently stored in the calibration memory.

8. Using the pneumatics of the PS-525 or an attached pressure standard, go to a pressure of 1013.25 mBar (sea level pressure of 0 feet), as read from the pressure standard. When the pressure is stable for approximately 30 seconds, note the pressure displayed on the PS-525 airspeed display in calibration mode.

If the displayed pressure is lower than the standard, press the Exit button as needed to incrementally raise the pressure to be equivalent to the standard.

If the displayed pressure is higher than the standard, press the Leak Check button as needed to incrementally lower the pressure to be equivalent to the standard.

As the pressure is adjusted, note that the displayed correction factor also changes. Use this to fine-tune the pressure as close as you can to the standard.

When the PS-525 pressure matches the standard as close as possible, wait another 30 seconds to ensure that the internal mathematical filtering corrections have been done.

If satisfied with the results, press the Units button to save the calibration and exit back to the mBar mode.

Note: Although the display calls out to use 1013.3 for the calibration point, it is not necessary to be at exactly that point. Any point +/- 10.00 mBar from 1013.3 may be used.

9. After the calibration point has been entered, the display will briefly read “**Storing New Cal**” and then re-start from the very beginning of the program as if the unit had just been turned on.

10. When a satisfactory calibration is obtained at this test point, go through each test point in the following chart, and enter the corrected value at each point. (The correction chart may be photocopied, cut out, and fixed to the test box for handy reference.)

11. If the calibration is not as exact as you would like, you can change the calibration factor up or down a little to get a better result. (Normally, the mBar of the pressure side should be about 0.1 mBar above the vacuum side, to prevent a display of “inverse pressure”.)

12. **Make a written note of the calibration correction value.** In the very rare case that a calibration factor is lost from the memory, it can be re-programmed without a complete calibration procedure. The correction value can also serve as a record to see if the sensors are drifting with age. A good place to keep the calibration correction values is in this manual.

Maximum allowable error at any airspeed is 2 Knots. (Generally, a maximum error of 1 Knot should be expected.)

Note: if the airspeed is out of calibration at a particular altitude range, and is correct in other ranges, it will indicate that the altimeter side has an incorrect calibration at that altitude. Correct this problem by re-calibrating the vacuum side, or re-entering the correction value for that altitude range.

The airspeed has only one calibration point.

| TEST AIRSPEED | DISPLAY AIRSPEED | TEST AIRSPEED | DISPLAY AIRSPEED |
|---------------|------------------|---------------|------------------|
| 40 Kts | | 250 Kts | |
| 60 Kts | | 275 Kts | |
| 80 Kts | | 300 Kts | |
| 100 Kts | | 325 Kts | |
| 120 Kts | | 350 Kts | |
| 140 Kts | | 375 Kts | |
| 160 Kts | | 400 Kts | |
| 180 Kts | | 425 Kts | |
| 200 Kts | | 450 Kts | |
| 225 Kts | | 500 Kts | |

Calibrated by: _____ Date: _____
 Next Calibration Due Date: _____

Calibration Notes:

- Do not forget to wait the minimum of 15 minutes before calibrating.
- The calibration procedure can be entered only when the mbar mode is selected.
- Do not forget to check bead colors in the air pressure reservoir/dryer. If they are pink, it is time to change the unit in order to avoid a build-up of moisture in the pressure system. Replacement air dryers can be purchased at many hardware stores, or on the internet (do a search for mini desiccant dryer).

Decoder Reader Calibration

There is no calibration necessary for the encoder reader circuitry. The Gray Code values are derived from look-down charts based on the input of the attached altitude encoder. Serial values are displayed based on the serial information that is sent from the altitude encoder to the decoder.

If proper operation needs to be verified, the following tests may be performed to show that each Gray Code input pin is working. Jumper each of the following pins, or combination of pins to ground (pin 15) and read the values as shown below:

| Pin(s) | Display |
|--------|----------|
| 11 | -800 ft |
| 12 | -1200 ft |
| 13 | -1000 ft |
| 1, 11 | 62300 ft |
| 2, 11 | 30300 ft |
| 3, 11 | 14300 ft |
| 4, 11 | 6300 ft |
| 5, 11 | 2300 ft |

Warning: Do not jumper pin 8 to ground, as this pin is the +12 or +24 VDC output. This will blow the fuse on the internal circuit board, and possibly more fuses on the power supply board. This may also create enough heat to burn the operator.

To verify proper operation of the serial codes, an altitude encoder will need to be connected and configured to test the various speeds and inputs.

Calibration of Reservoir Gauges

The reservoir gauges are for reference only, and do not need calibration. The operator merely references these gauges as an indication of how much reserve pressure or vacuum there is in the reservoirs, and as a guide to know when to turn on the pump(s).

CHAPTER 5

MAINTENANCE REPAIRS AND TROUBLESHOOTING

Note: Refer to the Theory of Operation section as a reference on how the various systems function.

Annual Maintenance

The following annual maintenance is recommended:

1. Check color of beads in air reservoir/dryer. Change if pink. The dryer is a common in-line dryer used in small air compressor systems. A new dryer can be purchased from Preston Pressure, or an internet search for “mini inline desiccant air dryer” may lead to an alternate source.
2. Feel fuses to verify tightness. If a fuse feels loose, remove the fuse, squeeze fuse clip slightly and re-install fuse. (There are 3 fuses on the power supply board and 1 on the main circuit board.)
3. Tug on motors to verify motors are mounted tightly. If play is noticed, disconnect batteries and connectors. Remove bottom assembly panel by removing the four nuts holding the bottom assembly. Tighten the motor mount screws and re-assemble.
4. Verify vacuum reservoir tank is mounted tightly.
5. Verify electrical connectors are seated completely.
6. Verify battery holding clamp is tight.
7. Verify switches and valves on front panel are mounted tightly.
8. Test for leaks.
9. Perform calibration checks, and re-calibrate if necessary.

• Troubleshooting

Refer to the following chart of symptoms, causes, and repair comments:

| SYMPTOMS | POSSIBLE CAUSES | COMMENTARY |
|--|--|---|
| Display shows garbage or freezes at the beginning display. | Microcontroller had a power brown-out or there is a low voltage condition. | 1. Turn off unit for 15 seconds before powering up again. 2. Re-cycle power switch. If |

| | | |
|-------------------------------------|--|---|
| | | problem occurs frequently, it may be caused by a loose or dirty internal connector. Check connectors to batteries and circuit boards. Also check for loose fuses. |
| Display never finishes initializing | <ol style="list-style-type: none"> 1. Tester is being operated in conditions that are excessively cold. 2. Low battery 3. If occurring on airspeed side, it is not receiving static pressure from vacuum sensor. | <ol style="list-style-type: none"> 1. Operate the tester in a warmer environment. 2. Re-charge battery. |
| Decoder flashes “LOW BATTERY” | <p>Battery voltage is low *See additional battery information below.</p> | <ol style="list-style-type: none"> 1. Connect charger. 2. If voltage is still low, or charge is rapidly lost, there is a defective battery. Test the voltage level across each battery and replace the battery with the lowest voltage. (Better still, replace both batteries.) 3. A fuse may be blown or loose on the power supply board. *See additional battery information below. |
| Motors do not work | <ol style="list-style-type: none"> 1. Low battery voltage *See additional battery information below. 2. Bad fuse 3. Bad switch or connectors 4. Bad solder joint or crimp terminal on motor 5. Bad motor(s) 6. Bad relay | <ol style="list-style-type: none"> 1. The relay on the power supply board will disconnect power to the motors when voltage drops below 18 volts. This is to protect battery life. (See Chapter 1 – Power Supply) 2. Replace fuse(s) 3. Check switches and connectors. Replace as needed. 4. Repair bad solder joint or crimp terminal. 5. Replace bad motor(s) 6. Power supply board relay can be replaced. |

| | | |
|--------------------------------------|---|---|
| Displays do not turn on | <p>1. Low voltage *See additional battery information below.</p> <p>2. Bad fuse(s)</p> <p>3. Bad wiring or connector</p> <p>4. Bad power switch</p> <p>5. Bad voltage regulator</p> | <p>1. Connect charger. If battery voltage remains low, or charge is rapidly lost, there is a defective battery. Test the voltage level across each battery and replace the battery with the lowest voltage. (Better still, replace both batteries.)</p> <p>2. Replace fuse(s)</p> <p>3. Check and repair as needed.</p> <p>4. Replace power switch.</p> <p>5. Replace voltage regulator. Note: the Altimeter and Airspeed circuits each have their independent 3.3 volt regulators, and the decoder uses a 5 volt regulator. However, all of the LCD displays operate at 5 volts, taken from the decoder regulator.</p> |
| Batteries do not take a charge | <p>1. Bad battery(s) *See additional battery information below.</p> <p>2. Bad power charger</p> <p>3. Bad fuse</p> <p>4. Bad power supply circuit</p> | <p>1. If battery charge is rapidly lost, there is a defective battery. Test the voltage level across each battery and replace the battery with the lowest voltage. (Better still, replace both batteries.)</p> <p>2. Replace power charger</p> <p>3. Replace bad fuse</p> <p>4. Repair power supply circuit (see schematic at end of this chapter).</p> |
| Display contrasting needs adjustment | Adjust variable resistor behind display. | Each display is adjusted independently. |
| No signal from known good encoder | 1. Fuse is blown on main circuit board | 1. Replace blown fuse. Note: If encoder works on 24 volts, but not on 12, the problem may be caused by a bad connector, wiring, or the power switch. |

| | | |
|--|---|--|
| | 2. Bad decoder circuitry | 2. Contact factory for further troubleshooting or repairs. |
| Unit will not vacuum up to 35,000 feet | 1. Leak in internal hoses or plumbing connectors 2. One motor is weak or inoperative | 1. Troubleshoot plumbing to find leak(s) 2. Replace defective motor |

*** Additional battery information:**

The two batteries are connected in series. This enables the unit to have a source of both +12 and +24 volts for the encoder. The +24 volts powers the electronic circuit board and, if selected, the encoder. If there is a battery failure, it is most likely to occur in the +12 volt battery side first. Both batteries should be changed, but while waiting for new batteries to arrive, you could attempt to temporarily use the unit by swapping the two batteries. This will place the stronger battery on the +12 volt side. If the batteries are not too damaged, this arrangement may provide temporary use of the tester.

If the +12 volt battery is shorted and damaged beyond use, another temporary alternative is to disconnect the batteries completely and use the test box with just the external power jack. This will cause the +12 volt from powering any encoder. But the test box should still be useable.

For replacement batteries, do an internet search for Power-Sonic PS-1230 batteries. There are several international sources for purchasing these batteries.

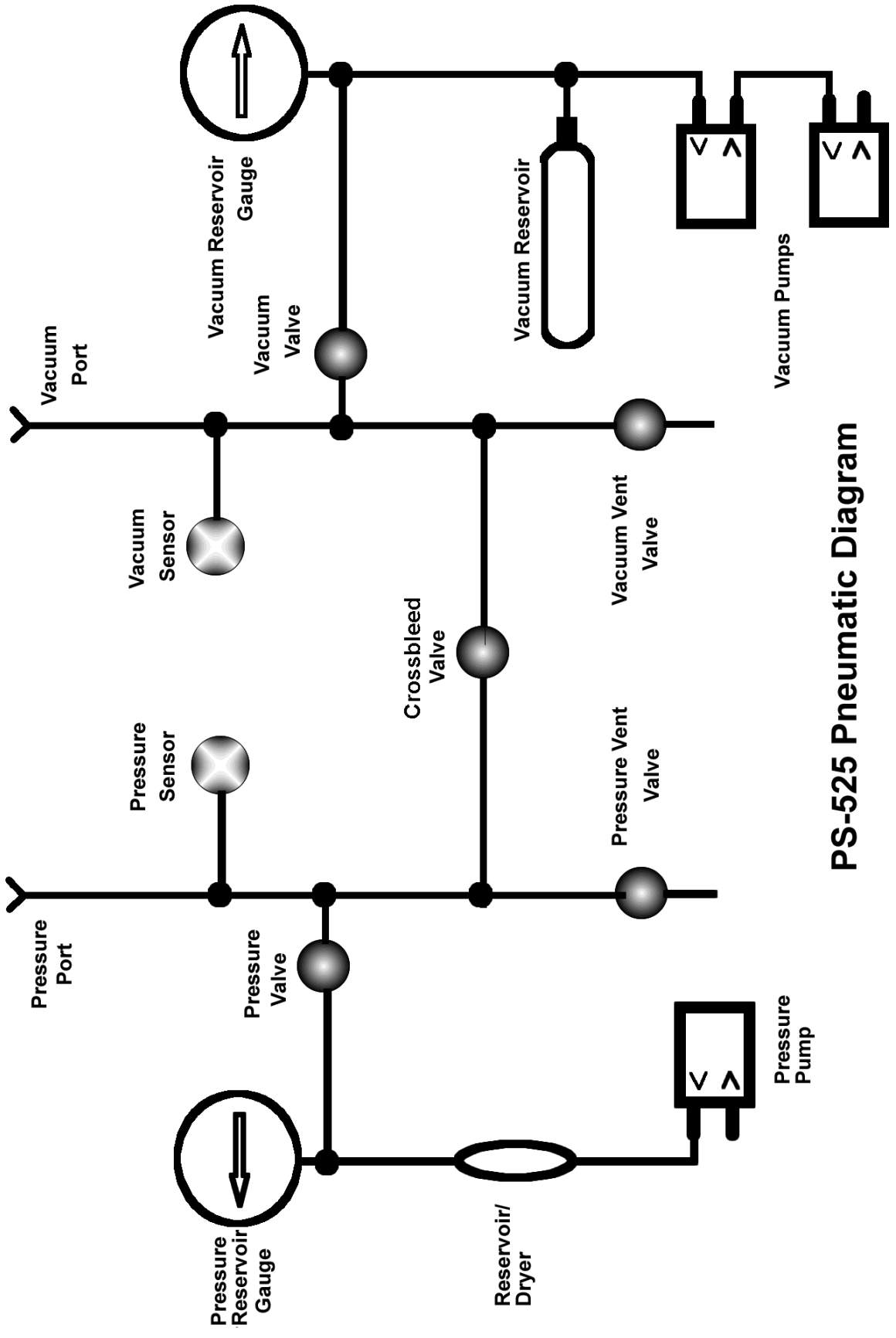

PS-525 Pneumatic Diagram

PS-525 Wiring Schematic

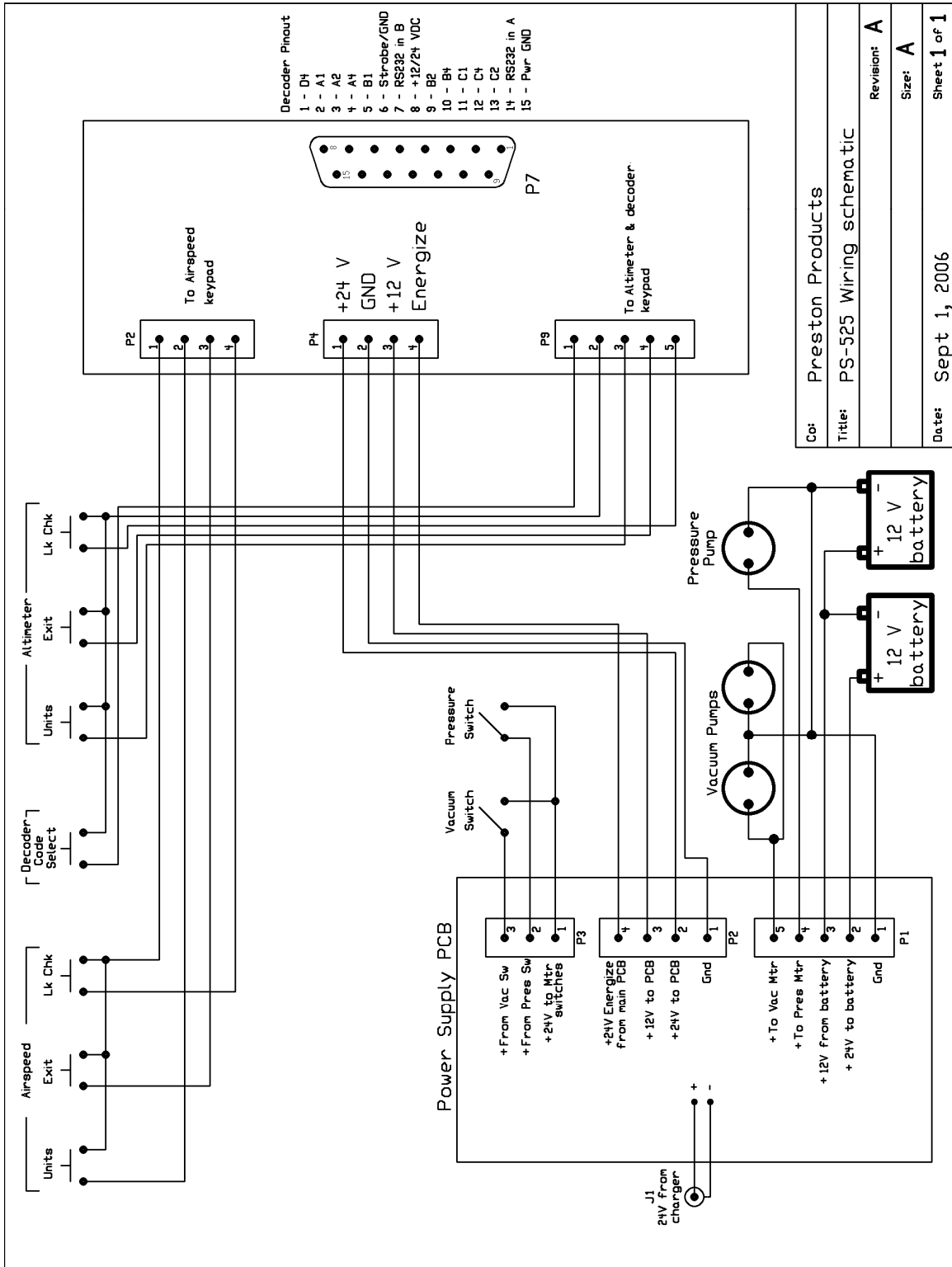

| | |
|-----------|-------------------------|
| Co: | Preston Products |
| Title: | PS-525 Wiring schematic |
| Revision: | A |
| Size: | A |
| Date: | Sept 1, 2006 |
| | Sheet 1 of 1 |

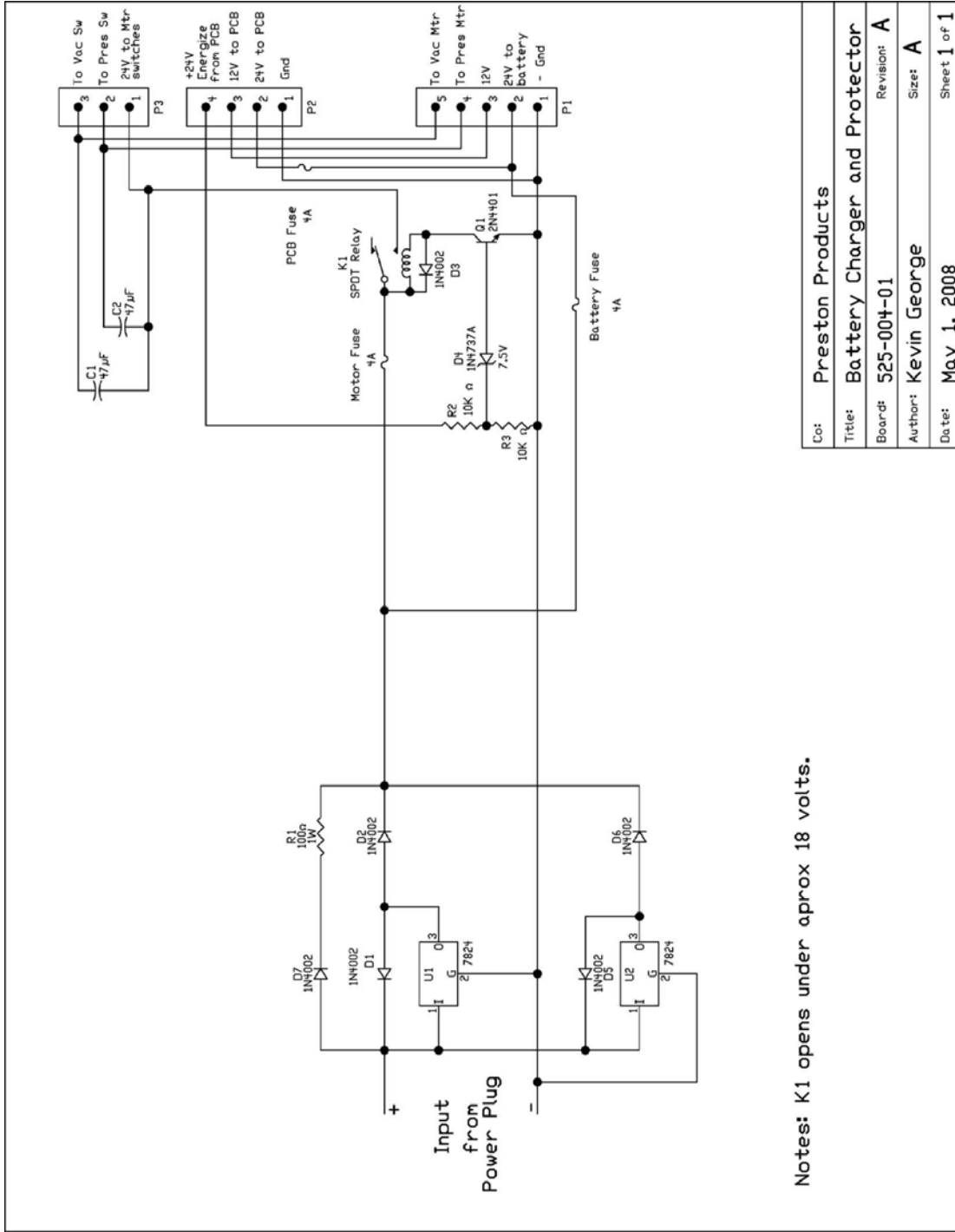

| | |
|-----------|-------------------------------|
| Co: | Preston Products |
| Title: | Battery Charger and Protector |
| Board: | 525-004-01 |
| Author: | Kevin George |
| Date: | May 1, 2008 |
| Revision: | A |
| Size: | A |
| Sheet | 1 of 1 |

CHAPTER 6

SHIPPING AND STORAGE

Shipping Instructions

- Partially open all valves
- Ensure power switch is off
- Package the test box inside another box, with at least 2 inches of packing material around the tester
- Do not forget to also enclose the battery charger/power supply
- Tester is not likely to be damaged with ground shipping if packaged properly

Storage Instructions

- Partially open all valves
- Place lid on tester
- Store the test set in a controlled environment
- If storage is to exceed 1 year, remove batteries from unit